

The ST2-20A is a light seeking tracker control designed for DC motor systems (typically linear actuators) with up to 48VDC maximum operating voltage (minimum operating voltage=10VDC, maximum allowable voltage=56vdc). In unobstructed sunlight it typically tracks within one degree of actual sun position. After the power up, the ambient light level will determine the operating mode.

The following "normal" operating modes apply:

- 1) Useable sun—the unit points toward highest illumination, which is usually the sun's disk but may be toward the horizon if there is substantial reflection from the ground, or the zenith on a bright overcast day.
- 2) Partially obscured sun (e.g. cumulous clouds with breaks)—unit pauses at last "valid" control point to wait for conditions to change.
- 3) Heavy overcast or night—unit moves to "park" position to await light level recovery.

The PARK position is determined by S1 section 2 OFF = park at EAST limit, S1 section 2 ON = park at WEST limit. S1 section 3 OFF = park at DOWN limit (array toward horizon), S1 section 3 ON = park at UP limit (array toward zenith).

Abnormal conditions—typically, motor failure or mechanical system jam (from ice build up) or heavy wind load: Tracker will attempt to move the array for 1 second. If motor overcurrent condition is sensed, tracker will terminate Drive and flash the PAUSE LED (at a half second rate) for 1 hour before attempting another move.

Indicators on the control PCB: PWR, PRK, PAUSE, TRACK, E/W DRIVE, UP/DN DRIVE, E/W & UP/DN LIMIT.

Notes on initial installation, power up and adjustments.

The remote sensor needs to be attached to the array frame such that the mounting surface of the sensor is parallel with the plane of the array—where on the array is not critical as long as the sensor receives unobstructed sun during the hours when the array is expected to track.

When power is applied, if the ambient light level is above the track threshold, it will then commence tracking unless S1-1 is in the RUN position, in which case there will be a 10 second delay.

Position trimpots RT1 and RT2 settings are to halt movement of the array under conditions of obscured sun where pause is not invoked. RT1 is for the azimuth (e.g. if the control commands west move with obscured sun, rotate RT1 counterclockwise and vice versa). RT2 is for the elevation (e.g. if the control commands an up move with obscured sun, rotate RT2 clockwise and vice versa). Note that the trimpots have a maximum rotation range of approximately 270 degrees. Use a light touch and small screwdriver if adjustment is necessary.

RT3 is to adjust the light level at which the tracker control changes from track to pause. Adjust clockwise for greater sensitivity (tracks at lower light levels).

S1 section 1 on the PCB controls the delay function. The idea here is that, during the initial installation, this is in the OFF (SETUP) position. In this state, everything happens “instantaneously”—a useful condition when tweaking the track trimpots and setting the PAUSE threshold. When S1-1 switch is in the ON (RUN) position (for normal, unattended operation), the following delays are added to the system operation:

A one minute delay is added to tracking corrections so that a request for a position change must remain constant for one minute to be considered valid. This is to reject transient events such as something flying over the sensor and, in cases where the sensor is shaded by moving vegetation during part of the tracking day, to hold off and/or reduce movement during back and forth shading events which aren't representative of true sun position and are not dark enough to invoke the PAUSE function.

A ten minute delay is added to the PARK movement. This is for conditions of changing cloud cover (where the sun occasionally pokes through) to keep the tracker from sending the array back and forth between PARK and TRACK positions. Light conditions must remain below PARK threshold for ten minutes before the controller will allow movement. (There is only a 10 second delay when changing from PARK to TRACK.)

S1 section 4 OFF: highest tracking accuracy. S1 section 4 ON: degraded accuracy to reduce oscillation or excessive searching during partly cloudy conditions.

The limit switches can be magnetically actuated reed switches or mechanically actuated type. They are “normally open” and close when drive system nears limit of non-destructive travel. If your actuators have built-in limit switches, the limit switch inputs to the control can be “not connected” and the tracker control will function properly.

To limit total power dissipation, only one axis is driven at a time. The moving axis locks out the other one until its move is complete. If limit switch activation stops one axis, the other axis will also be halted. When PARK is being executed, Elevation and Azimuth drives are time shared at 20/40 seconds each.

The tracker control PCB needs to be housed indoors or in a weatherproof enclosure.

When power is first applied, all of the status indicators illuminate for one second for function verification.

Notes on mounting the light sensor: The highest overall accuracy is obtained when the (trimpot) position trimming results in the central quad of light sensors being uniformly shaded by the center shadow disc. In situations where highest accuracy is desired, this can be achieved by tweaking the mechanical mounting of the light sensor housing (interactively with the trimpots) to get uniform shading when "on track".

If the control wanders off to an extreme under obscured sun conditions, use trimpot adjustments to get system to stop at some "neutral" position close to the sun's disc.

DO NOT use the light sensor cable strain relief nut to mount the light sensor, as this can compromise the mechanical and hermetic integrity of the unit and cause failure.

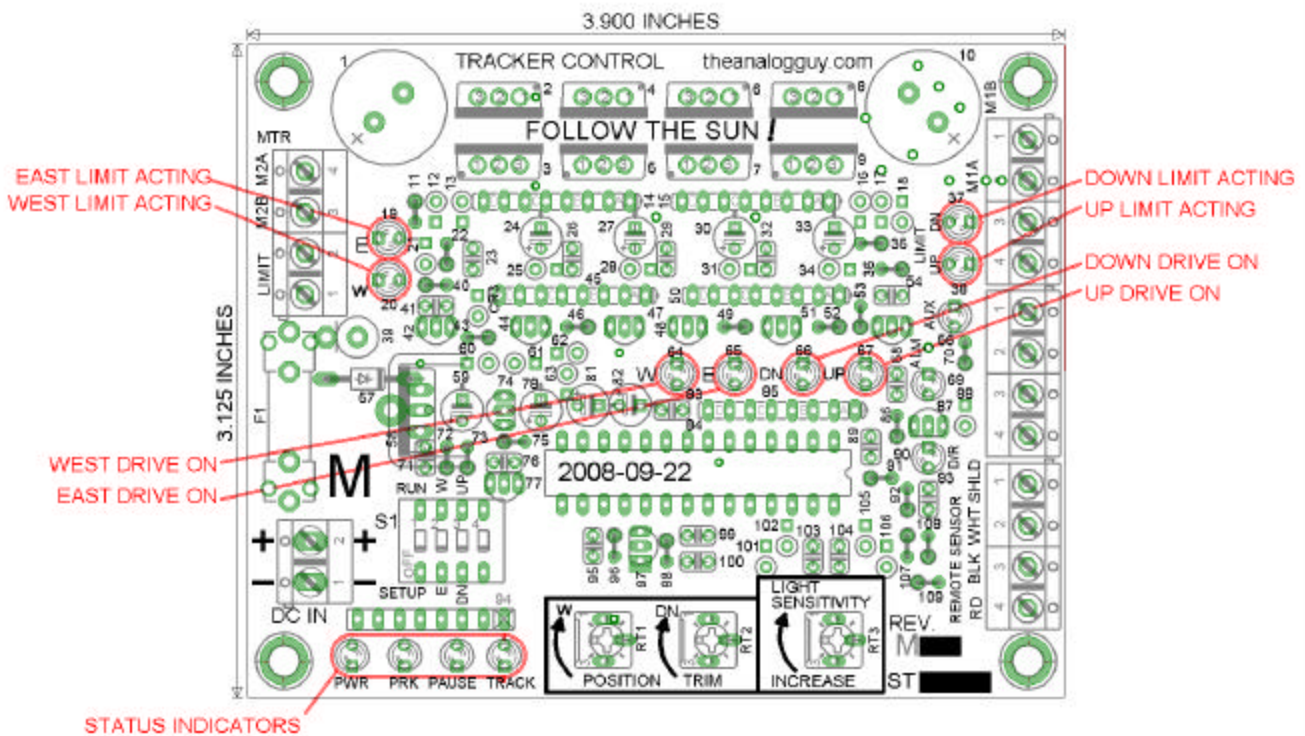

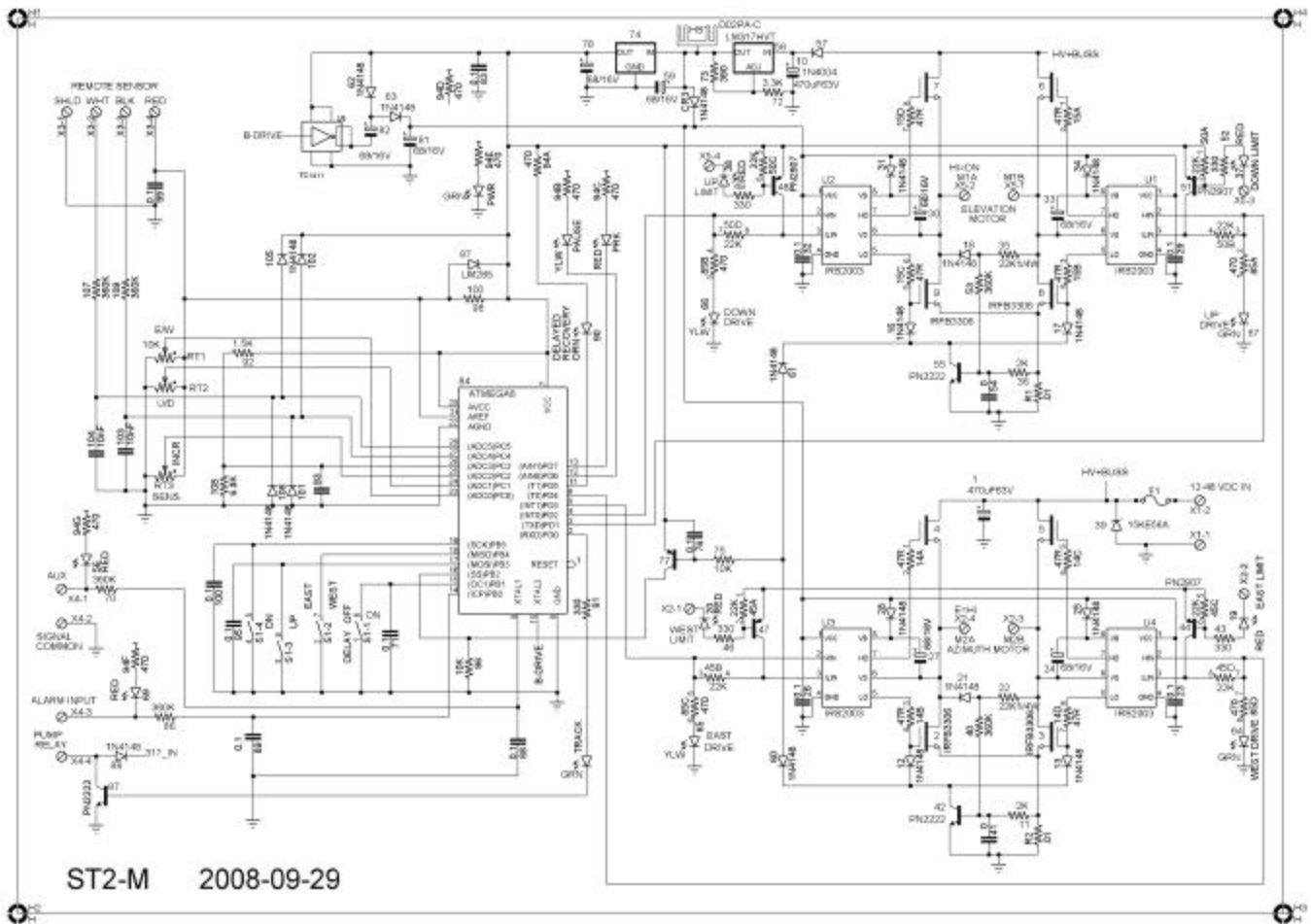

note: schematic represents a "superset" and all components shown may not be on your model—also, some component values vary between models.

Revisions

2010-03-09: "limit" wording added to park description. RT1, RT2 function description changed.